

ELEVATOR TRIM - MAINTENANCE PRACTICES

1. General

- A. Elevator trim maintenance practices consist of elevator trim system removal/installation, elevator trim system rigging, elevator trim tab free play inspection, elevator trim tab actuator disassembly, elevator trim tab actuator inspection and repair, elevator trim tab actuator lubrication and assembly and elevator trim tab actuator inspection and rigging.

2. Elevator Trim System Removal/Installation

- A. Remove Elevator Trim System (Refer to Figure 201).

- (1) Remove carpet or vinyl cover, plywood floor covers, floorboard and horizontal stabilizer access plates or covers, and upholstery panel at entrance to tailcone.
- (2) Remove connector links; detach chain from cables.
- (3) Remove nut and washer. Detach trim wheel from shaft.
- (4) Detach chain from sprockets and remove sprocket from shaft.
- (5) Remove screw from pedestal. Detach pointer, spacer, and bushing.
- (6) Remove nuts, washers, bolts, and bushings; detach sprockets from support.
- (7) Remove bolt and washer. Detach pulley from support.
- (8) Remove nuts, washers, and bolts. Detach pulleys from supports.
- (9) Airplanes 20800001 Thru 20800185 and 208B0001 Thru 208B0214 except airplanes incorporating SK208-76, remove nuts, washers, and bolts, detach fairleads from supports.
- (10) Remove nut, washer, and bolt. Detach pulleys from support.
- (11) Remove nuts, washers, and bolts. Detach stop blocks from cables.
- (12) Remove safety wire or clips from turnbuckles.
- (13) Detach turnbuckle from cables.
- (14) Detach turnbuckle from cables.
- (15) Remove bolts and washer. Detach pulleys from supports.
- (16) Remove connector links from chain. Detach chain from cables.

NOTE: To ease removal and installation of cables, attach a length of wire opposite removal end of cable. When cable is removed, leave wire in place, routed through structure. Pull replacement cable into correct location with wire.

- (17) Remove cables from system.
- (18) Remove safety wire and bolts. Detach sprocket guards from actuators.
- (19) Remove cotter pins, nuts, bushings, and bolts. Detach pushrods from actuators and horns.
- (20) Remove chains from actuator sprockets.
- (21) Remove safety wire and bolts. Detach actuators from supports, and remove through stabilizer access port.
- (22) Remove plug buttons and groove pins. Detach actuator sprockets from actuators.

- B. Install Elevator Trim System (Refer to Figure 201).

- (1) Attach actuator sprockets to actuators. Install groove pins and plug buttons.
- (2) Install actuators in stabilizers. Attach actuators to supports. Install bolts and safety wire.
- (3) Secure trim tabs in streamlined position. Attach pushrods to horn and actuator. Install bushings, bolts, nuts, and cotter pins. Release trim tabs.

NOTE: Torque nuts to 10 inch-pounds, then overtorque until first cotter pin slots line up with holes in bolts.

- (4) Attach chains on sprockets with connector link ends of chains equidistant from centerline of outboard sprockets.

WARNING: Pitch of sprockets must be synchronized with pitch of chain. Do not place unequal load on pushrods. Sprockets are provided with two sets of mounting holes and may have to be removed and replaced in a different set of holes to synchronize with pitch of chain.

- (5) Attach sprocket guards to actuators. Install bolts. Safety wire bolts.

- (6) Install cables in system.
- (7) Attach cable to chains. Install connector links.
- (8) Attach pulleys to support. Install washers and bolts.
- (9) Attach bushing, spacer, and pointer to pedestal. Install screw.
- (10) Attach sprocket to shaft.
- (11) Attach sprockets to support. Install bushings, bolts, washers, and nuts.
- (12) Attach chain to sprockets and with connector link ends of chain centered.
- (13) Attach trim wheel to shaft. Install washer and nut.
- (14) Attach chain to cables. Install connector links.
- (15) Attach pulleys to support). Install washer and bolt.
- (16) Attach pulleys to supports. Install bolts, washers, and nuts.
- (17) Airplanes 20800001 Thru 20800185 and 208B0001 Thru 208B0214 except airplanes incorporating SK208-76, attach fairleads to supports. Install bolts, washers, and nuts.
- (18) Attach pulleys to support. Install bolt, washer, and nut.
- (19) Attach stop blocks to cables. Install bolts, washers, and nuts. Refer to Elevator Trim System Rigging.
- (20) Attach turnbuckle to cables.
- (21) Attach turnbuckle to cables.
- (22) With trim tabs streamlined, tighten turnbuckles evenly until cable tension checks 20 pounds, +5 or -5 pounds. Safety wire or install clips on turnbuckles.
- (23) Install tailcone upholstery panel, floorboard access covers and vinyl cover or speed tape access covers, and plywood floor covers.

3. Elevator Trim System Rigging

- A. Rig Elevator Trim System (Refer to Figure 201).

NOTE: All control surface cable tensions should be rigged at an ambient temperature of 70°F. Allow temperature to stabilize for a period of four hours before setting cable tension.

- (1) Remove upholstery panel at entrance of tailcone.
- (2) With elevator pinned at neutral, set the elevator trim tab at 0 degrees.
- (3) Secure trim tabs in streamlined position (faired with the elevator), and attach an inclinometer on left tab. Set at zero degrees.
- (4) Cut safety wire or remove clips and loosen turnbuckles.
- (5) Check that chains are centered on sprockets.
- (6) Check pointer. If it does not indicate neutral trim, loosen nut and washer and disengage trim wheel from shaft far enough to set pointer on neutral.
- (7) Tighten nut on washer and trim wheel.
- (8) Tighten turn buckles evenly and set cable tension at 20 pounds, +5 or -5 pounds. Safety wire or install clips on turnbuckles.
- (9) Measure 28 inches aft from bulkhead and set stop block on cable. Install bolt, washer, and nut.
- (10) Release trim tabs and rotate trim wheel forward until inclinometer checks 15 degrees, +2 or -2 degrees.
- (11) Attach stop block to cable in contact with stop block. Install bolt, washer, and nut.
- (12) Rotate trim wheel aft until inclinometer checks 15 degrees, +2 or -2 degrees.
- (13) Attach stop block to cable in contact with stop block. Install bolt, washer and nut.
- (14) Check pointer through 15 degrees in each direction of travel. If required, bend pointer slightly to clear pedestal cover.
- (15) Verify correct tab movement in response to trim wheel movement.
- (16) Remove inclinometer from elevator trim tab and install upholstery panel at entrance to tailcone.

4. Elevator Trim Tab Actuator Disassembly (Airplanes with 2660017-1 Trim Tab Actuator Installed)

- A. Disassemble Elevator Trim Tab Actuator (Refer to Figure 202).

- (1) Cut safety wire and remove bolts; remove chain guard from actuator housing. Remove plug buttons from secondary sprockets. Detach repair link and remove chain from sprockets.
- (2) Remove groove pins and sprockets from internal screws.
NOTE: It may be necessary to apply heat to sprocket to loosen Loctite seal between sprockets and internal screws.
- (3) Place index marks on bearings and actuator housing. Remove groove pins and from actuator housing and remove bearings and from actuator housing. Remove and discard O-rings from bearings.
NOTE: If bearings are to be reused, they must be replaced in the same location and relative position from which they were removed.
- (4) Tap ends of external screws on table top to remove bearings, races, bearings, and washers. Discard washers.
- (5) Tap internal screws at ends "B" and remove internal screws from actuator housing and separate bearings, races, washers and external screws from internal screws. Discard washers.

5. Elevator Trim Tab Actuator Disassembly (Airplanes with 2661215-1 or 2661215-9 Trim Tab Actuator Installed)

A. Disassemble Trim Tab Actuator (Refer to Figure 202).

- (1) Remove the safety wire from the chain guard bolts.
- (2) Remove the bolts, chain guard and spacers from actuator housing.
- (3) Remove plug buttons from sprockets.
- (4) Detach repair link and remove chain from sprockets.
- (5) Remove groove pins from the sprockets.
- (6) Remove the sprockets from the internal screws.
NOTE: It may be necessary to apply heat to sprocket to loosen Loctite seal between sprockets and internal screws.
- (7) Remove screw and end plate.
- (8) Remove the countersunk screws.
NOTE: The screws that are countersunk are installed with Loctite. These may be difficult to remove. If normal loosening techniques will not free the screws, applying some heat may help. Do not force the screws loose, the screw head may break. Instead, use a drill and easy-out to remove the screws. This will avoid damage to the end plate.
- (9) Remove screw and slide end plate up external screws.
- (10) For actuator 2661215-1, tap the ends of the external screws on table top to remove wipers and bearings.
NOTE: If bearings are to be reused, keep the two halves together as a pair as they are removed. They must be replaced in the same location and relative position from which they were removed.
- (11) For actuator 2661215-9, tap the ends of the internal screws on table top to remove wipers and bearings.
NOTE: The bearings are shank sealed on the actuator 2661215-9.
NOTE: If bearings are to be reused, keep the two halves together as a pair as they are removed. They must be replaced in the same location and relative position from which they were removed.
- (12) Unscrew the external screws from the internal screws.
 - (a) For actuator 2661215-9, remove the O-ring from the external screw.
- (13) Tap internal screws at the sprocket end to remove the bearings.
 - (a) Check condition of bearings; replace if required, utilizing an arbor press and mandrel.
- (14) Remove internal screws from actuator housing.
- (15) Clean actuator components and dry thoroughly. DO NOT clean bearing. DO NOT allow cleaned parts to contact lint or dirt.

6. Elevator Trim Tab Actuator Inspection/Repair

A. Inspect/Repair Elevator Trim Tab Actuator (Refer to Figure 202).

- NOTE: Remove actuator from system. Clean, inspect, and lubricate detail parts. Replace any components that show damage or excessive wear. Refer to Chapter 5 for Time Limits.**

- (1) Clean detail parts with solvent in a well ventilated area away from sparks or open flame. Avoid inhalation of solvent vapors.
- (2) Dry parts with dry compressed air, lint free cloth, or lint free disposable tissue.
- (3) Check parts visually, preferable under magnification. If any parts show wear or damage, perform a dimensional check and replace parts, if necessary.
- (4) If finish on actuator housing or chain guard has worn away or bare metal is exposed, apply Iridite 14-2, followed by two coats of epoxy primer.
- (5) The finish shall consist of vivid orange or white lacquer.

7. Elevator Trim Tab Actuator Lubrication and Assembly (Airplanes with 2660017- 1 Trim Tab Actuator Installed)

A. Lubricate and Assemble Trim Tab Actuator (Refer to Figure 202).

NOTE: Lubricate each detail part of actuator assembly before installation with 5565450-28 light consistency silicone grease, which may be purchased from Cessna Parts Distribution.

- (1) Install new O-rings in bearings.
- (2) Install internal screws with ends "B" up and actuator housing in upright position with end "C", down.
- (3) Install races, washers, bearings, washers, and bearings. Locate bearings on index marks and lightly tap or press them into actuator housing until groove pins can be installed through actuator and bearings.
- (4) Place actuator housing in upright position with end "C" up.
- (5) Install races, washers, bearings and bearings in actuator housing. Ensure bearings are located on index marks, and lightly tap or press them into actuator housing until groove pins can be installed through housing and bearings.

NOTE: Steps through are applicable if existing bearings and are utilized. If new bearings are required, steps through are applicable.

- (6) Heat-soak new bearings in SAE 20-weight oil for 20 minutes at 140°F. Cool bearings to ambient temperature before installation.
- (7) Install internal screws in actuator housing with ends "B" up and actuator housing in upright position with end "C" down.
- (8) Install races, bearings and a 0.004 to 0.006 inch shim on ends "B" of internal screws.
- (9) Install bearings, press or tap lightly until bearings are flush with end of actuator housing.
- (10) Place actuator housing in upright position with bearings on bottom.
- (11) Install races, bearings and bearings in actuator housing. Press or tap lightly until bearings are flush with end of actuator housing.
- (12) Place a clamp securely across assembled bearings to prevent any linear movement of internal screws.
- (13) Drill 0.094 inch diameter holes (4 places) through existing 0.062 inch diameter holes in actuator housing and through bearings.
- (14) Release clamp and remove bearings and 0.004 to 0.006 inch shim from actuator housing.
- (15) Install bearings and install new 0.094 inch groove pins (4 each) through actuator housing and bearings.
- (16) Install external screws in actuator housing at end "C".

NOTE: After external screw threads contact internal screw threads, ensure they are not cross-threaded, and turn external screws approximately 25 turns clockwise after threads engage. Engagement should be smooth with no tight spots. If threads drag or tight spots are observed, disassemble actuator and install internal and external screws.

- (17) Apply No. 609 Loctite to mating surfaces of sprockets and internal screws. Install sprockets and install groove pins and plug button.

8. Elevator Trim Tab Actuator Lubrication and Assembly (Airplanes with 2661215-1 or 2661215-9 Trim Tab Actuator Installed)

A. Lubricate and Assemble Elevator Trim Tab Actuator (Refer to Figure 202).

- (1) Prior to assembly, apply a 1/8 inch coating of 5565450-28 light consistency silicone grease, which may be purchased from Cessna Parts Distribution, on the threads of internal screws, the outer surface of internal screws, and the outside diameter of external screws.
- (2) Install bearings into the actuator housing.

- (3) Put the internal screws into the actuator housing.
- (4) Install the end plate on the actuator housing with screw.
NOTE: After installation of end plate, outer race of bearing must not move in actuator housing.
- (5) Lubricate threads of the external screw.
- (6) Heat the wipers to make more pliable.
NOTE: Be very careful not to damage the wipers when installing them over threads of the external screw.
- (7) Position end plate and wipers over external screws.
 - (a) Inspect wipers to ensure threads do not damage wipers during installation.
NOTE: Make sure the flat side of wiper is seated into bearing recess.
- (8) For actuator 2661215-9, install the O-ring on the external screws.
- (9) Screw the external screws into the internal screws.
NOTE: After external screw threads contact internal screw threads, ensure they are not cross-threaded, and turn external screws all the way in. Engagement should be smooth with no tight spots. If threads drag or tight spots are observed, disassemble actuator and install internal screws and external screws.
- (10) For actuator 2661215-1, position the bearing halves around the external screws and press the bearings into the actuator housing.
- (11) For actuator 2661215-9, position the bearing halves around the external screws.
NOTE: Make sure that the O-ring is in the groove of both bearing halves.
 - (a) Shank seal the bearing halves with Type X Class B sealant and press them into the actuator housing.
- (12) Push the wipers into position in the bearing halves.
- (13) Install the screws that attach the end plate on to actuator housing.
 - (a) Safety wire screw .
- (14) Apply No. 609 Loctite to mating surfaces of sprockets and internal screws.
- (15) Install the sprockets on to the internal screws .
 - (a) Install the groove pins.
- (16) Apply common RTV sealant to plug buttons and sprockets.
 - (a) Install the plug buttons in sprockets.
- (17) Work the screws all the way in and out 2 to 3 times, wipe excess grease from both ends after each cycle.
NOTE: There must be no end play between bearing inner race, internal screw and sprocket when groove pins are installed.
NOTE: After assembly, maximum longitudinal movement of external screws and actuator housing is not to exceed 0.007 inch.
- (18) Install chain guard and spacers on to the actuator housing using bolts.
 - (a) Safety wire the bolts.

9. Elevator Trim Tab Actuator Inspection and Rigging (Airplanes with 2660017-1 Trim Tab Actuator Installed)

- A. Inspect and Rig Elevator Trim Tab Actuator (Refer to Figure 202).
 - (1) After assembling detail parts, rotate sprockets clockwise, then counterclockwise far enough to obtain approximately 0.75 inch linear movement of external screws in each direction. Movement should be smooth in each direction with no perceived torque change in either direction.
 - (2) Bearings in external screws must be aligned within 0.010 inch before installing actuator in system.
NOTE: A surface plate or table, four threaded rods or bolts (2 10-24 NC 3A thread and 2 1/4-20 UNC 2B thread), V-blocks, angle block, clamps and height gage and dial indicator or equivalent precision measuring equipment are required to perform preceding check.
 - (3) Attach bolts or threaded rods to both sides of actuator housing at points "D". Bolts or rods should be tightened.

- (4) Mount unit in V-blocks in vertical position.
- (5) Rotate either external screw in required direction to allow installation of No. 11 drill rod (0.191 inch diameter) through both bearings.
- (6) Check dimension from top of bolts or rods at points "D" to top of No. 11 drill rod outside of each bearing.
- (7) Remove No. 11 drill rod and rotate either screw in required direction. Install No. 11 drill rod through bearings and check alignment. Continue rotating screw(s) as required to align bearings within 0.010 inch.

NOTE: If bearings cannot be aligned to 0.010 inch with chain removed, rotate either sprocket one or two teeth in desired direction. Sprockets have two sets of mounting holes located 75 degrees apart. It may be necessary to move sprocket from one set to the other.

NOTE: If it is determined elevator trim tab excessive free play is caused by actuator, internal screws and external screws must be replaced along with any detail part worn beyond dimensional tolerance. However, if special optical inspection equipment is available and it is verified threads on internal screws and external screws are not worn beyond dimensional tolerance, screws may be reinstalled in assembly.

- (8) Install chain on sprockets and install connector link.
- (9) Install chain guard on actuator housing and install screws. Safety wire screws.

10. Elevator Trim Tab Actuator Inspection and Rigging (Airplanes with 2661215-1 or 2661215-9 Trim Tab Actuator Installed)

A. Rig and Inspect Elevator Trim Tab Actuator (Refer to Figure 202).

- (1) After assembling detail parts, rotate sprockets clockwise, then counterclockwise far enough to obtain approximately 0.75 inch linear movement of external screws in each direction. Movement should be smooth in each direction with no perceived torque change in either direction.

NOTE: Starting torque of primary sprocket shall not exceed 3 inch-pounds at ambient temperature of 65°F.

- (2) Bearings in external screws must be aligned within 0.010 inch before installing actuator in system.

NOTE: A surface plate or table, four threaded rods or bolts (2 10-24 NC 3A thread and 2 1/4-20 UNC 2B thread), V-blocks, angle block, clamps and height gage and dial indicator or equivalent precision measuring equipment are required to perform preceding check.

- (3) Attach bolts or threaded rods to both sides of actuator housing at points "D". Bolts or rods should be tightened.
- (4) Mount unit in V-blocks in vertical position.
- (5) Rotate either external screw in required direction to allow installation of No. 11 drill rod (0.191 inch) through both bearings.
- (6) Check dimension from top of bolts or rods at points "D" to top of No. 11 drill rod outside of each bearing .
- (7) Remove No. 11 drill rod and rotate either screw in required direction. Install No. 11 drill rod through bearings and check alignment. Continue rotating screw(s) as required to align bearings within 0.010 inch.

NOTE: If bearings cannot be aligned to 0.010 inch with chain removed, rotate either sprocket one or two teeth in desired direction. Sprockets have two sets of mounting holes located 75 degrees apart. It may be necessary to move sprocket from one set to the other.

NOTE: If it is determined elevator trim tab excessive free play is caused by actuator, internal screws and external screws must be replaced along with any detail part worn beyond dimensional tolerance. However, if special optical inspection equipment is available and it is verified threads on internal screws and external screws are not worn beyond dimensional tolerance, screws may be reinstalled in assembly.

- (8) Install chain on sprockets and install connector link.
- (9) Install chain guard and spacers on actuator housing and install bolts. Safety wire bolts.

Figure 201 : Sheet 1 : Elevator Trim System Installation

A22555

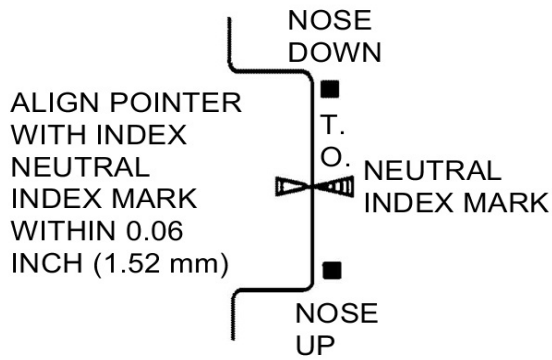
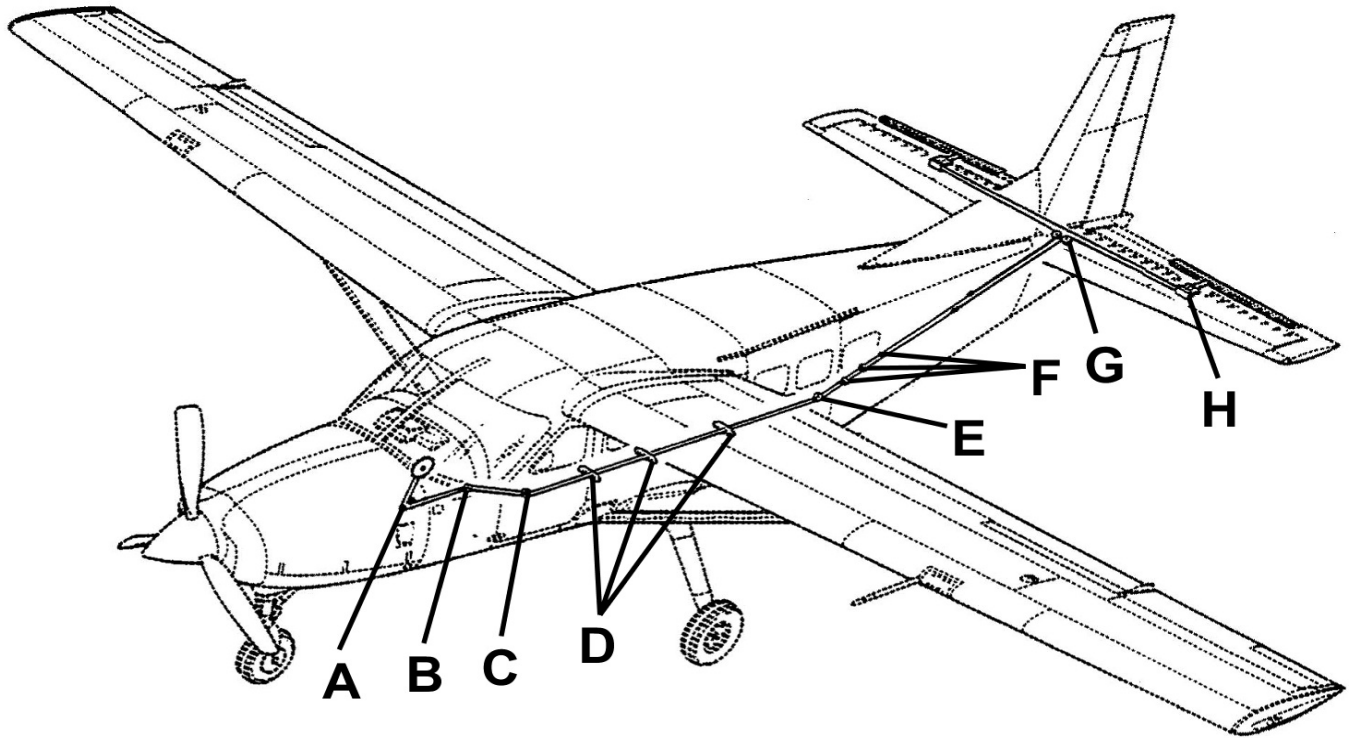

AIRPLANES 20800123 AND ON AND
 AIRPLANES 208B0001 AND ON

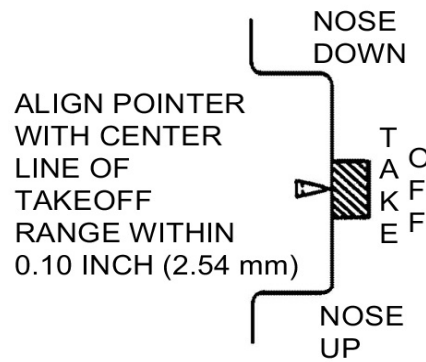

AIRPLANES 2080001 THRU 20800122

26641004
 2618X1157

Figure 201 : Sheet 2 : Elevator Trim System Installation

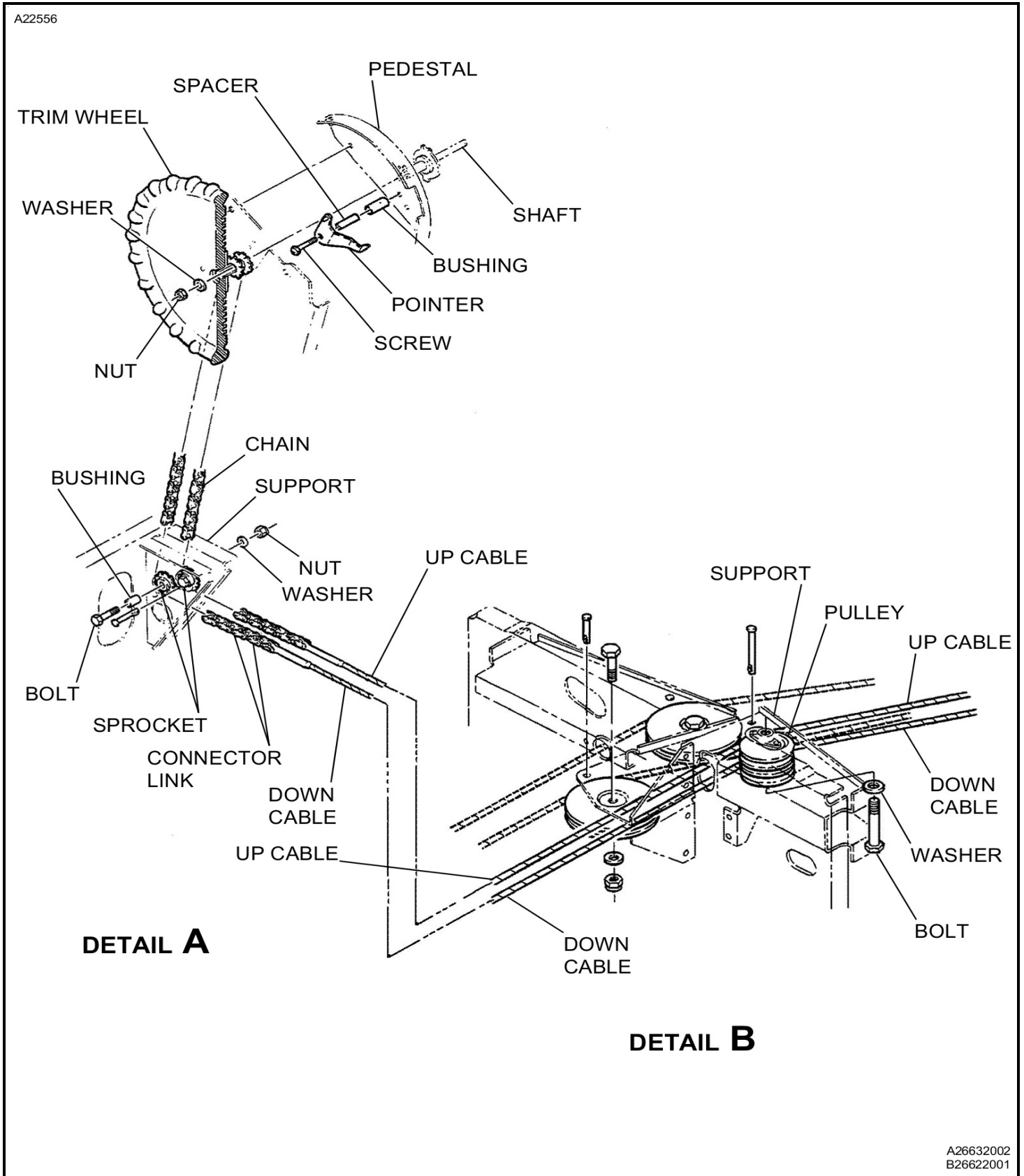

A26632002
B26622001

Figure 201 : Sheet 3 : Elevator Trim System Installation

A22557

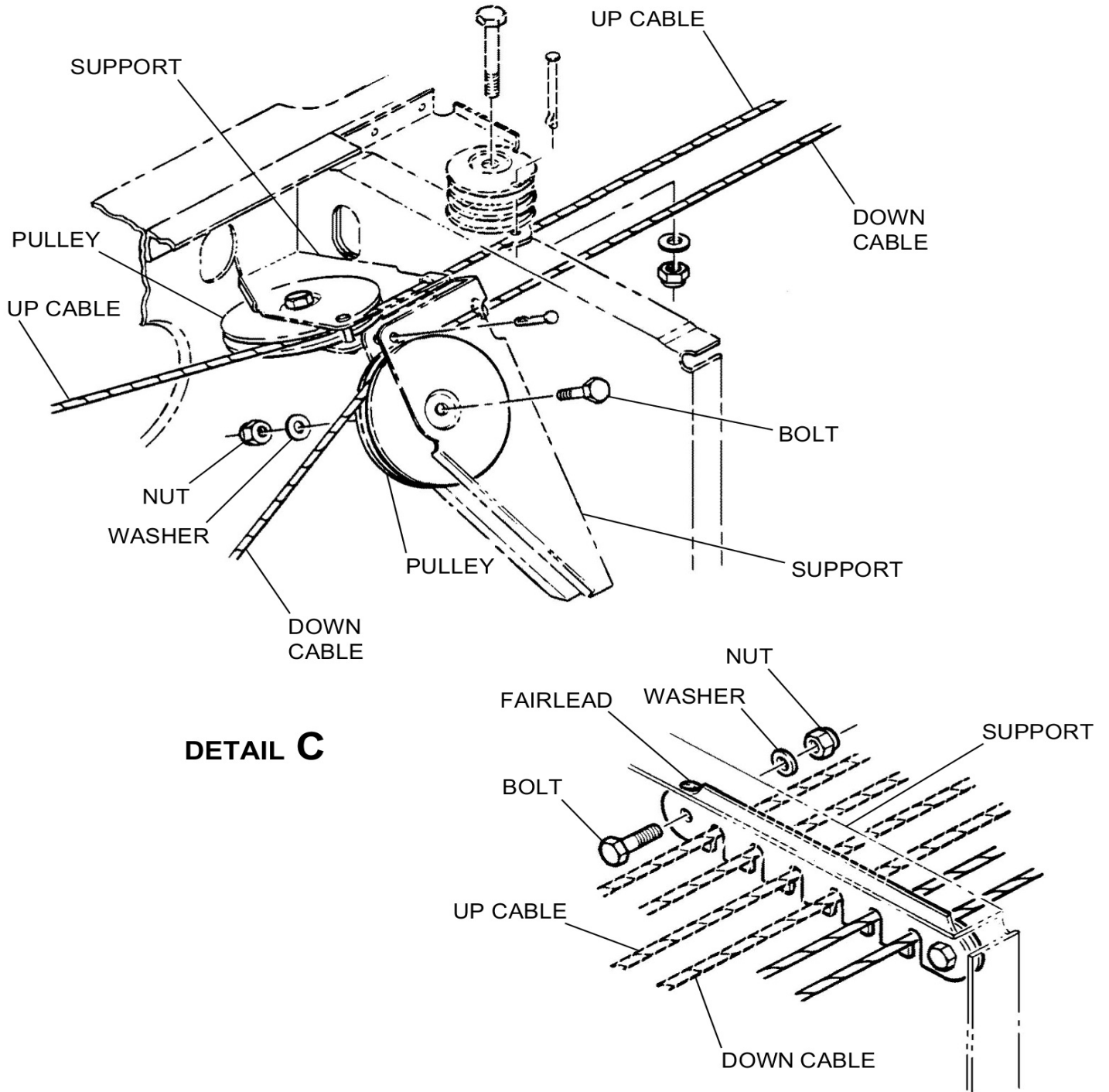

DETAIL C

DETAIL D

AIRPLANES 20800001 THRU 20800185 AND
AIRPLANES 208B0001 THRU 208B0214
EXCEPT AIRPLANES INCORPORATING SK208-76

C26632013
D26631019

Figure 201 : Sheet 4 : Elevator Trim System Installation

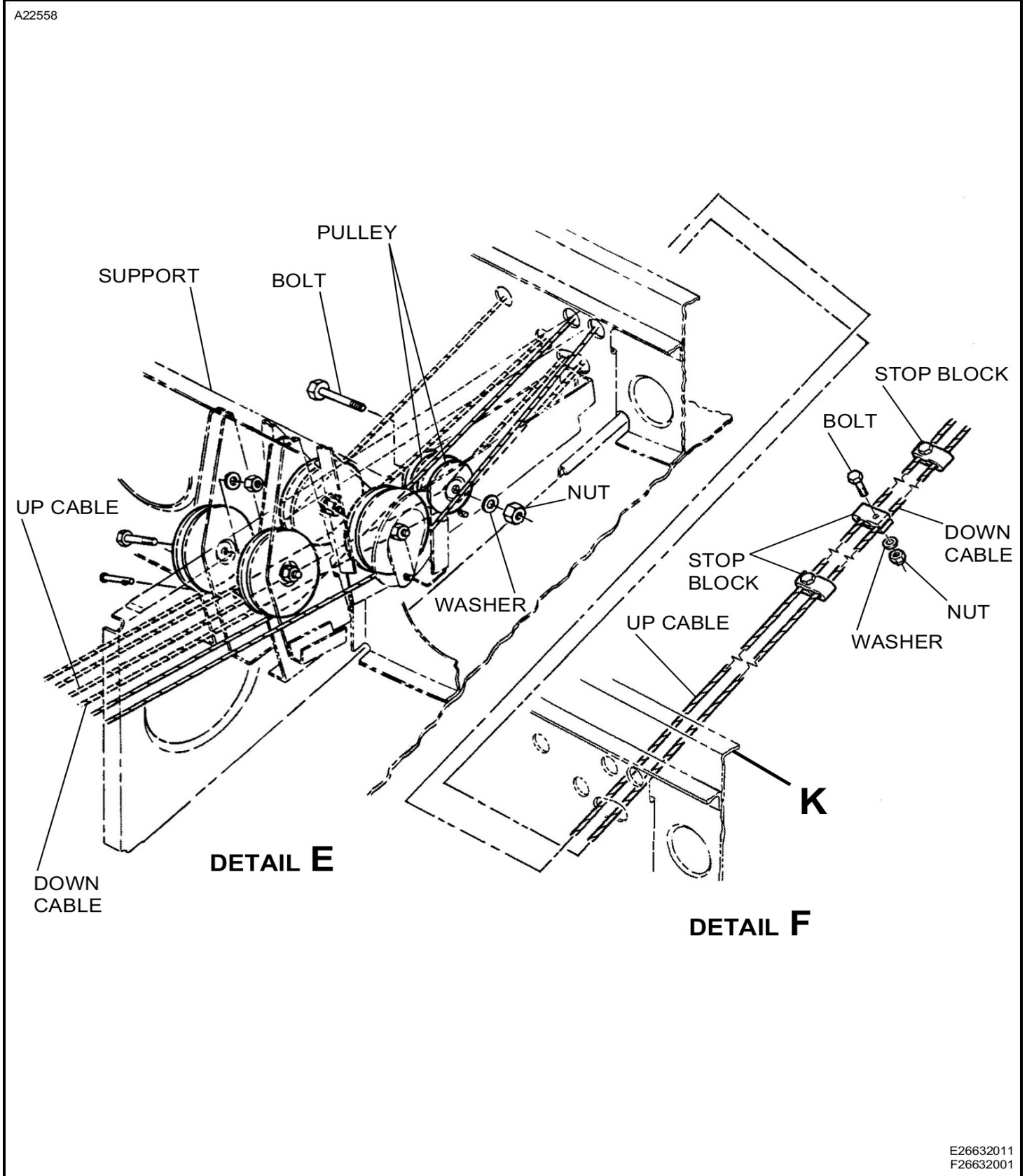

E26632011
F26632001

Figure 201 : Sheet 5 : Elevator Trim System Installation

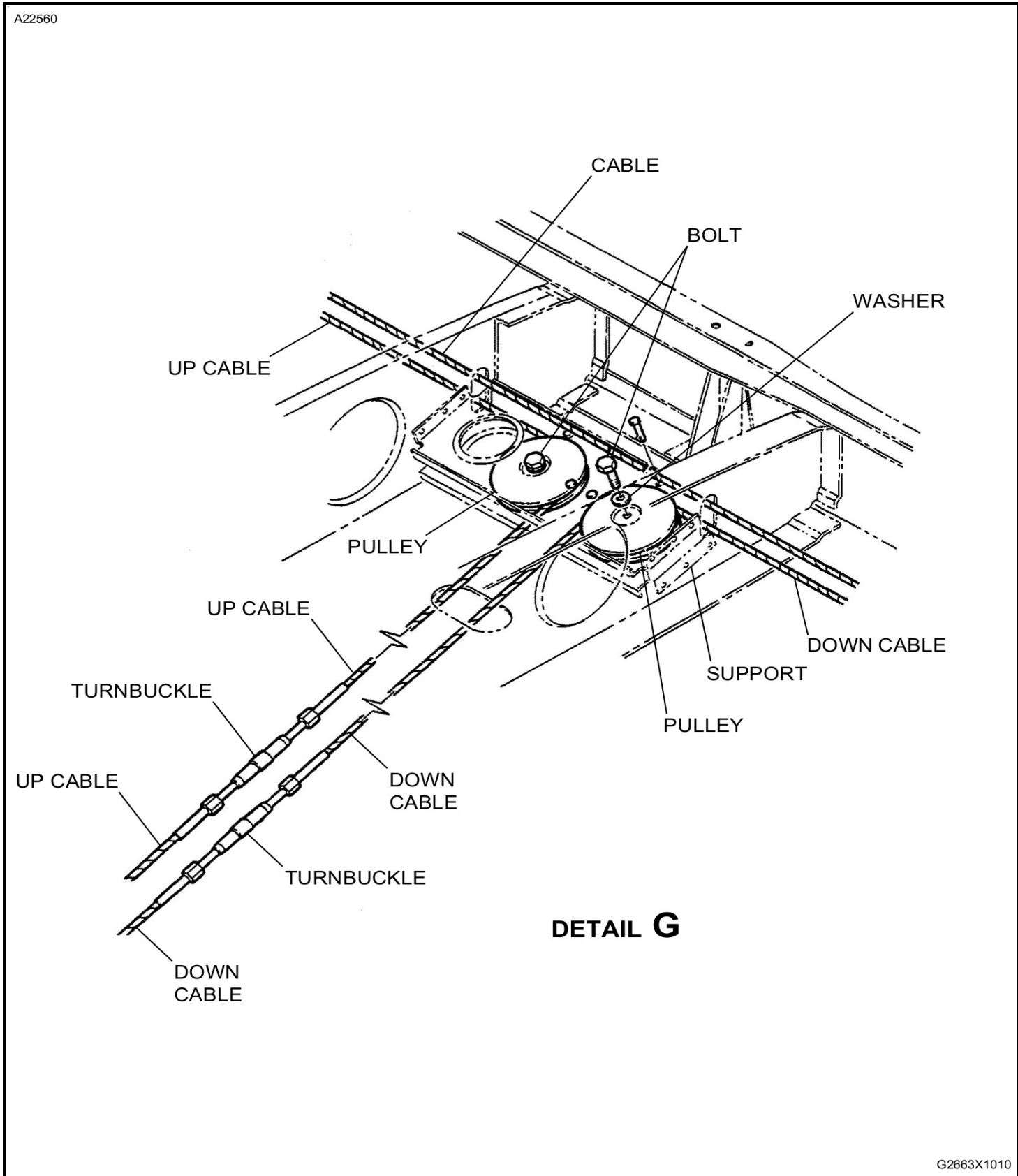

Figure 201 : Sheet 6 : Elevator Trim System Installation

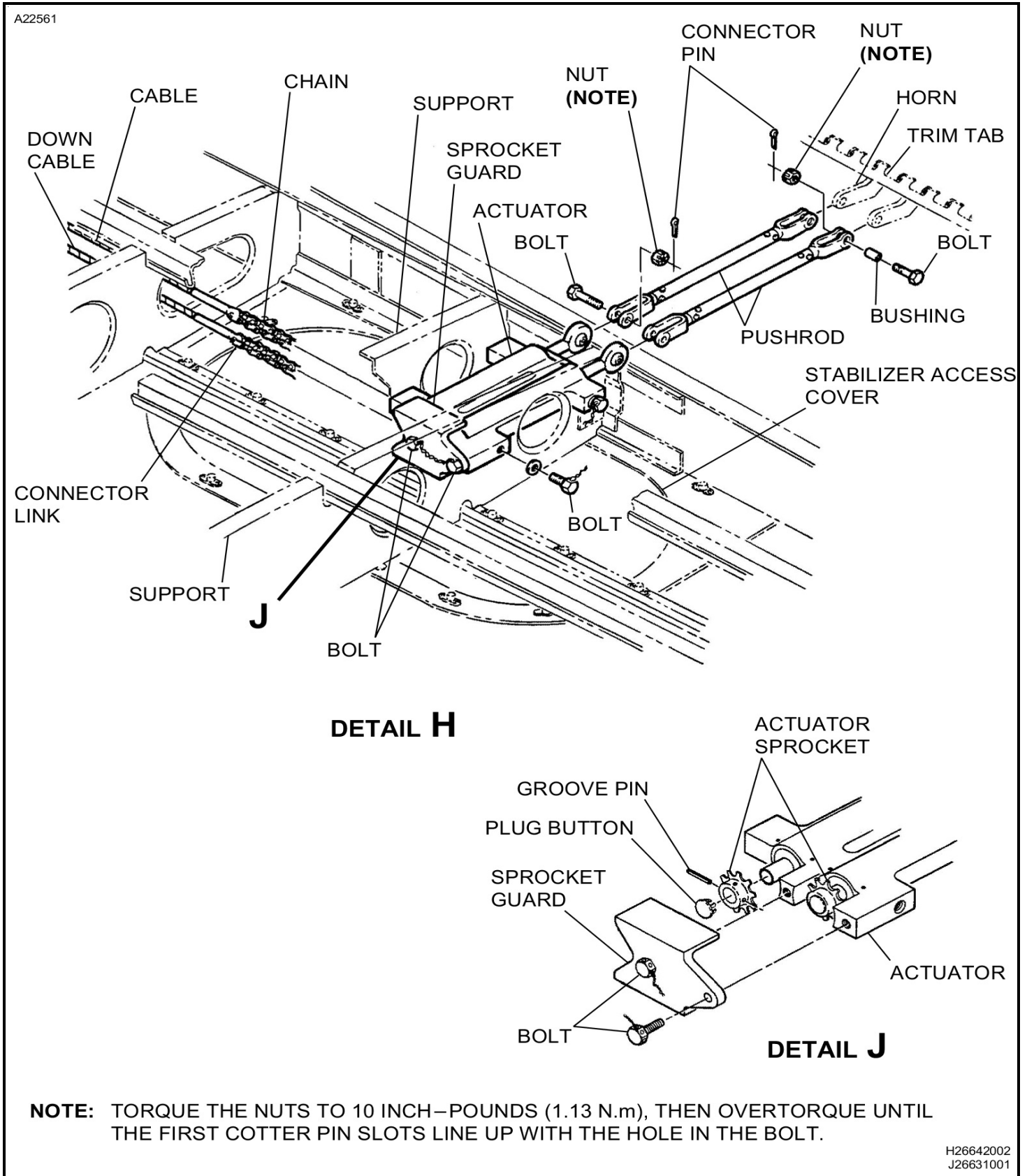
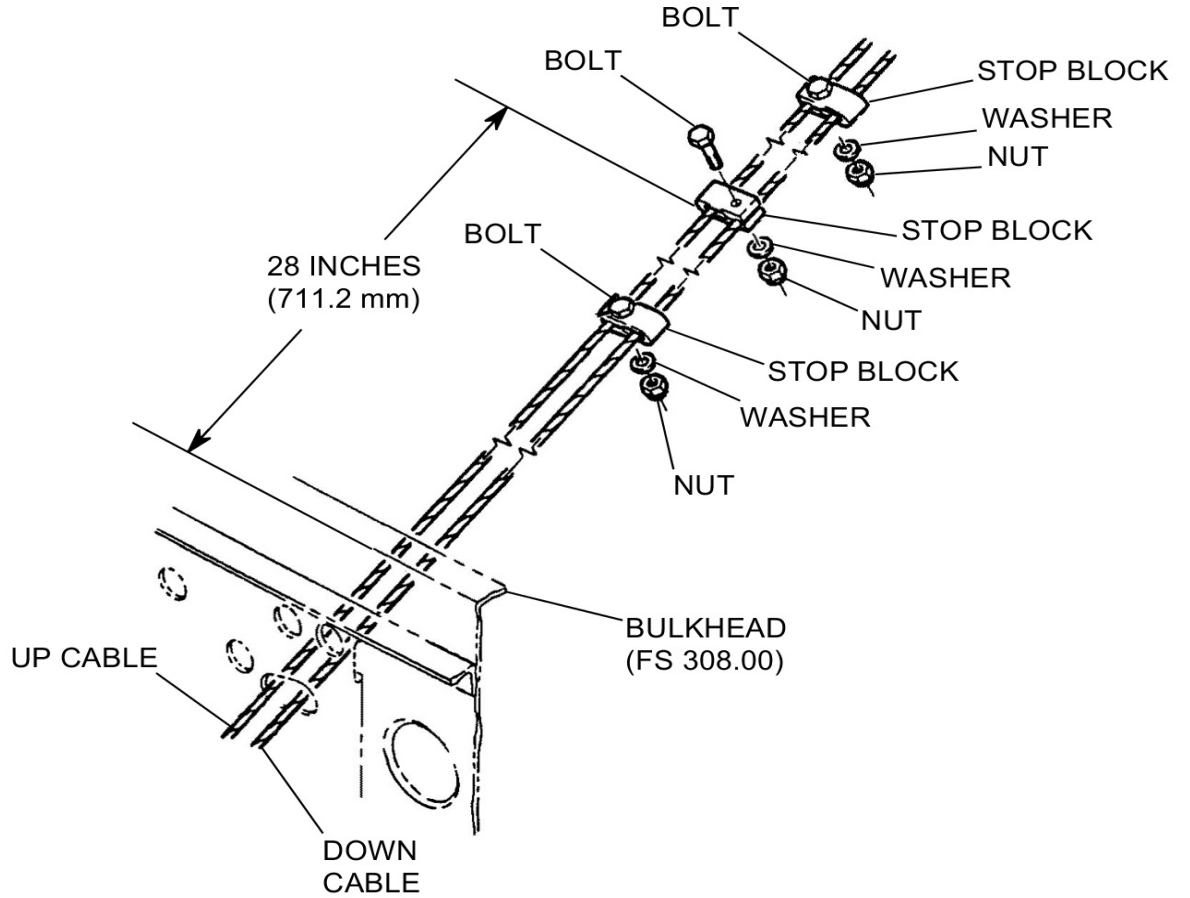

Figure 201 : Sheet 7 : Elevator Trim System Installation

A22562



DETAIL K

K2663X1007

Figure 201 : Sheet 8 : Elevator Trim System Installation

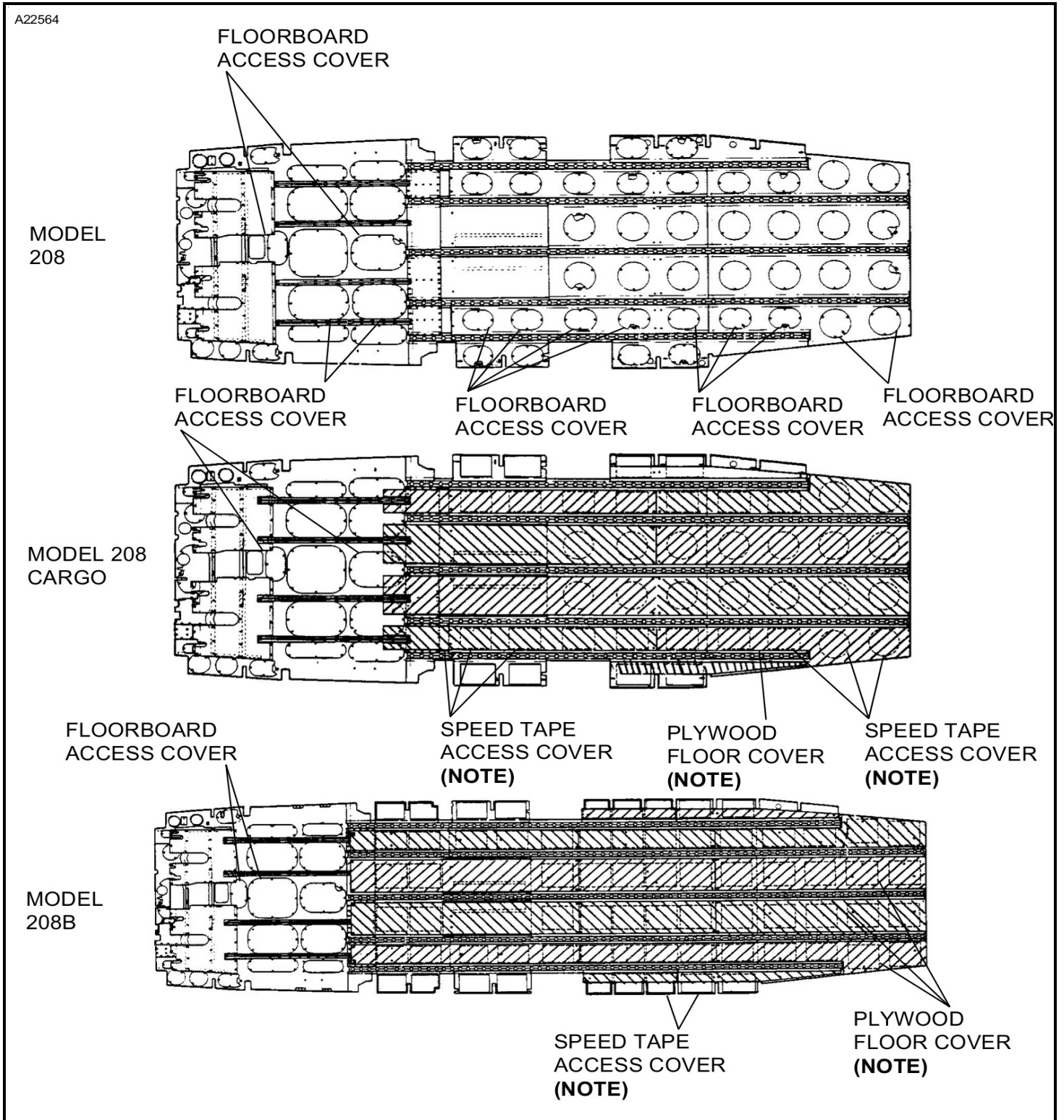

NOTE: REFER TO CHAPTER 53 FOR APPROPRIATE INSTRUCTIONS CONCERNING REMOVAL AND INSTALLATION OF PLYWOOD FLOOR COVERS AND SPEED TAPE ACCESS COVERS ON MODEL 208 CARGO AND 208B AIRPLANES.

26114003

Figure 202 : Sheet 1 : Elevator Trim Tab Actuator

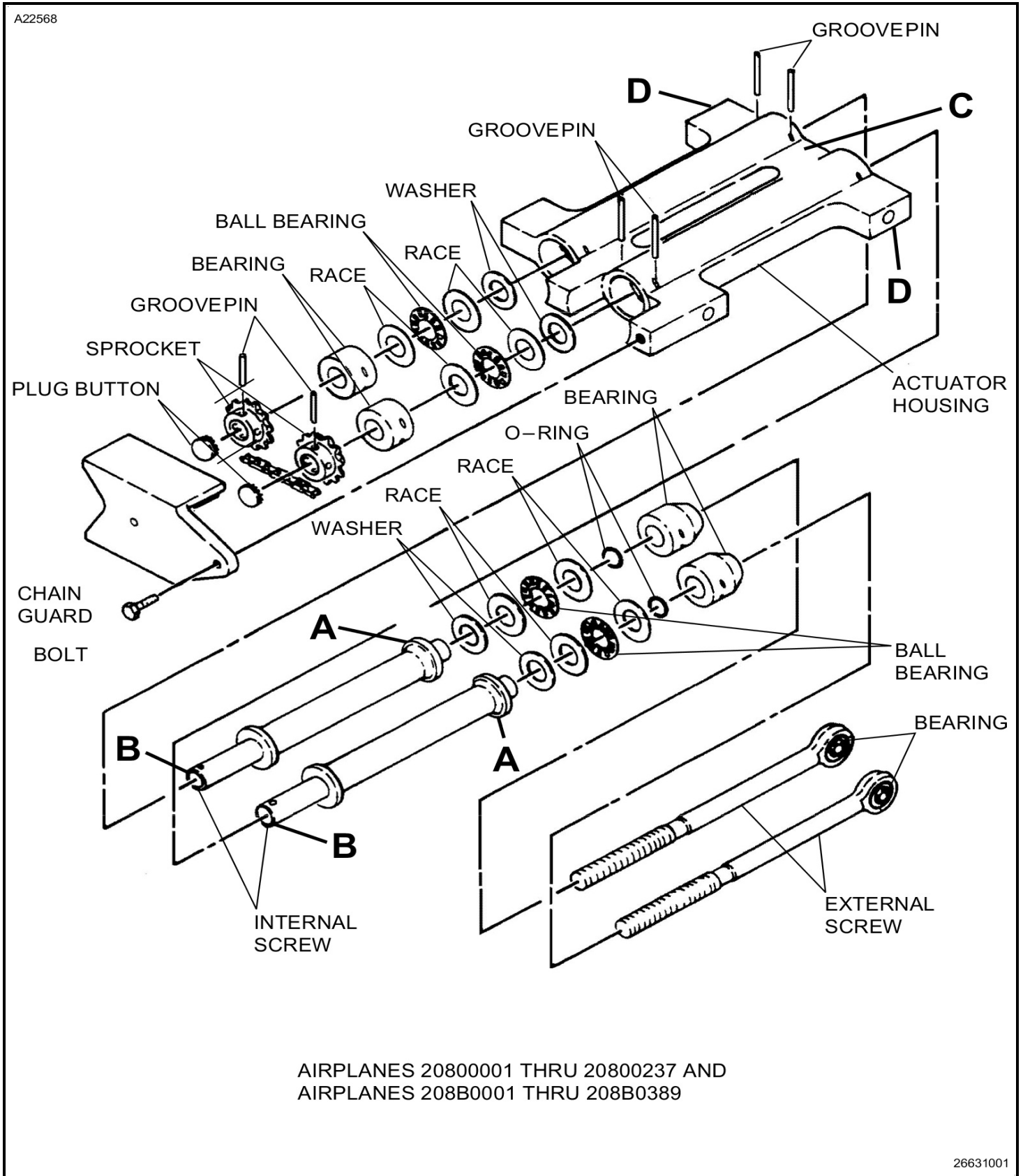
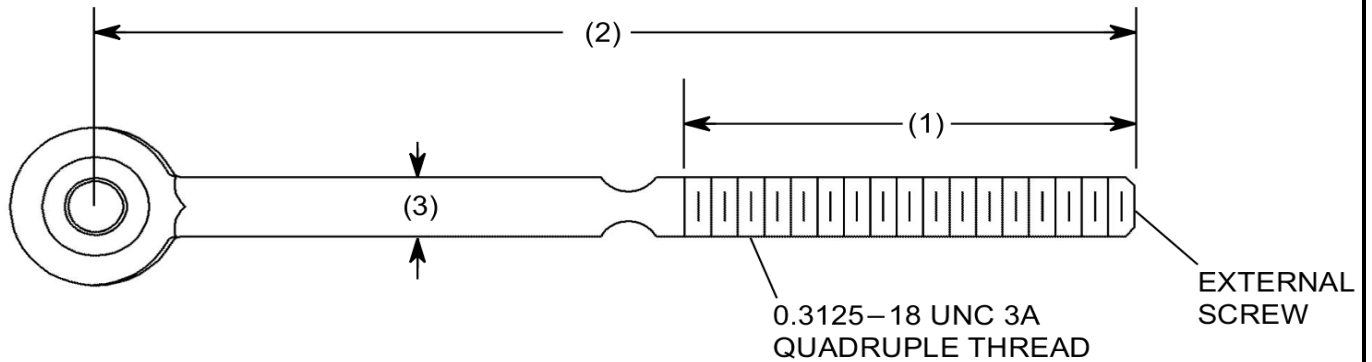
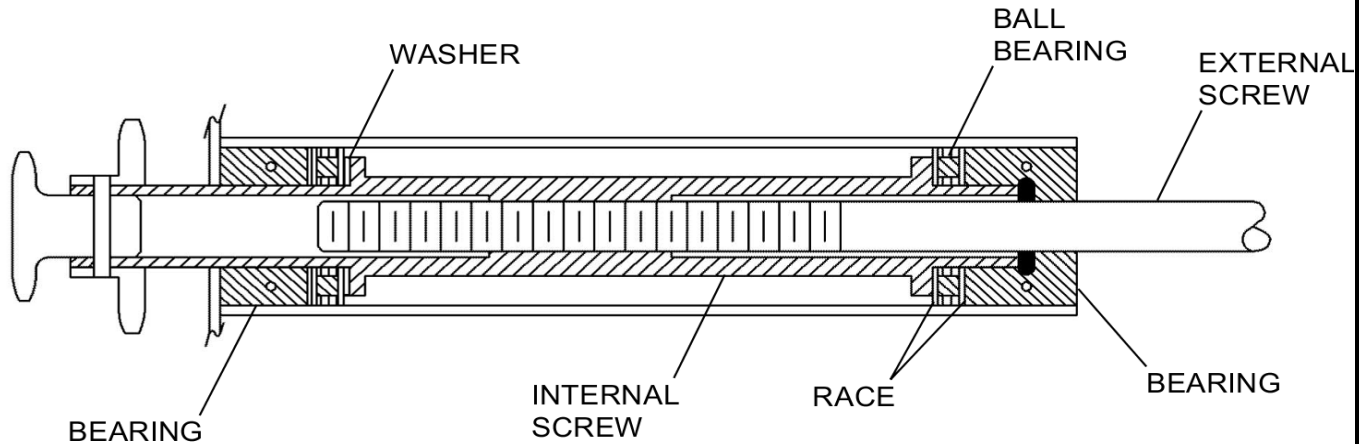

Figure 202 : Sheet 2 : Elevator Trim Tab Actuator

A22559



ROD MUST BE STRAIGHT WITHIN
 0.0003 INCH (0.0076 mm) AND CONCENTRIC
 WITHIN 0.002 INCH (0.051 mm) TRUE
 INDICATOR READING.

(1) 2.00 INCHES (50.8 mm)

(2) 5.60 INCHES (142.24 mm)

(3) 0.3075 INCH, +0.0010 OR -0.0000 INCH (7.810 mm, +0.025 OR -0.000 mm) DIAMETER

AIRPLANES 20800001 THRU 20800237 AND
 AIRPLANES 208B0001 THRU 208B0389

5596C1007
 5596C1022

Figure 202 : Sheet 3 : Elevator Trim Tab Actuator

A22563

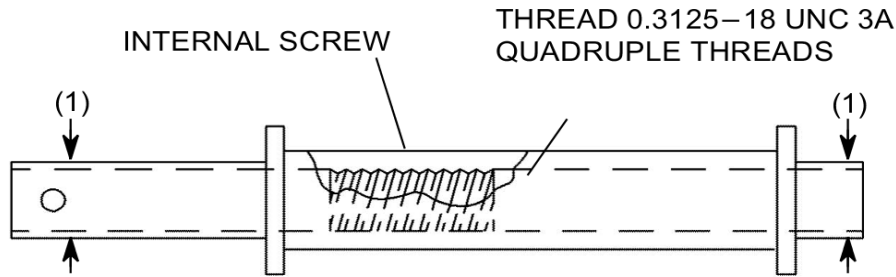

(1) 0.375 INCH, +0.000 OR -0.001 INCH (9.525 mm, +0.000 OR -0.025 mm) DIAMETER

BEARING

BEARING

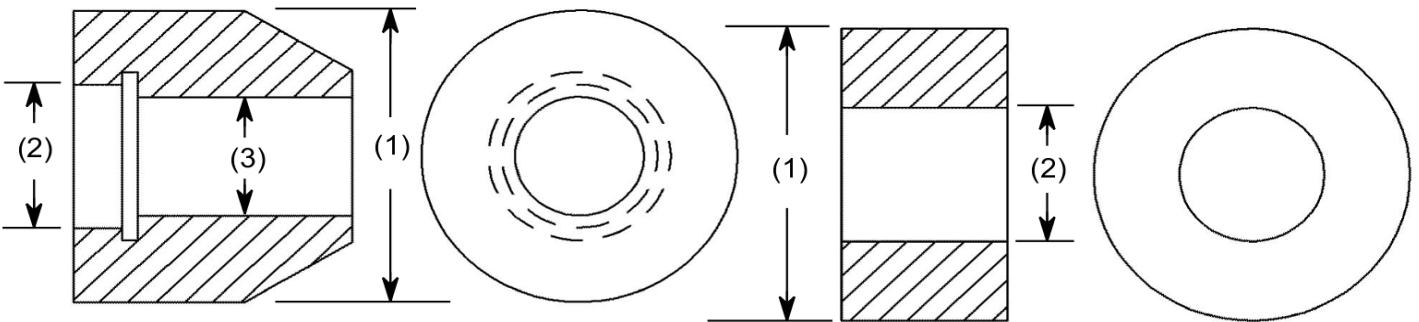

(1) 0.828 INCH, +0.000 OR -0.001 INCH
(21.03 mm, +0.000 OR -0.025 mm) DIAMETER **(NOTE)**

(1) 0.828 INCH, +0.000 OR -0.001 INCH
(21.03 mm, +0.000 OR -0.025 mm)
DIAMETER

(2) 0.383 INCH, +0.001 OR -0.001 INCH
(9.728 mm, +0.025 OR -0.025 mm) DIAMETER **(NOTE)**

(2) 0.383 INCH, +0.001 OR -0.001 INCH
(9.728 mm, +0.025 OR -0.025 mm)
DIAMETER

(3) 0.311 INCH, +0.001 OR -0.000 INCH
(7.900 mm, +0.025 OR -0.000 mm) DIAMETER **(NOTE)**

NOTE: (1) MUST BE CONCENTRIC TO (2) AND (3) WITHIN 0.002 INCH (0.051 mm) TOTAL INDICATOR READING.

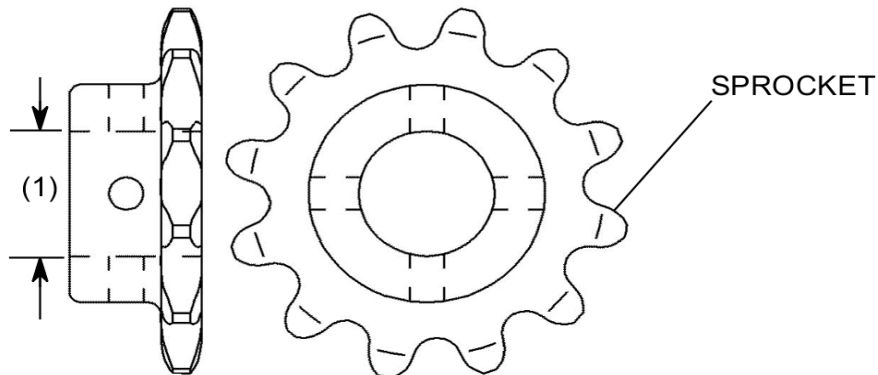

(1) 0.3775 INCH, +0.000 OR -0.000 INCH (9.588 mm, +0.000 OR -0.000 mm) DIAMETER

AIRPLANES 20800001 THRU 20800237 AND
AIRPLANES 208B0001 THRU 208B0389

5596C1009
5596C1006
5596C1006
5596C1021

Figure 202 : Sheet 4 : Elevator Trim Tab Actuator

A22565

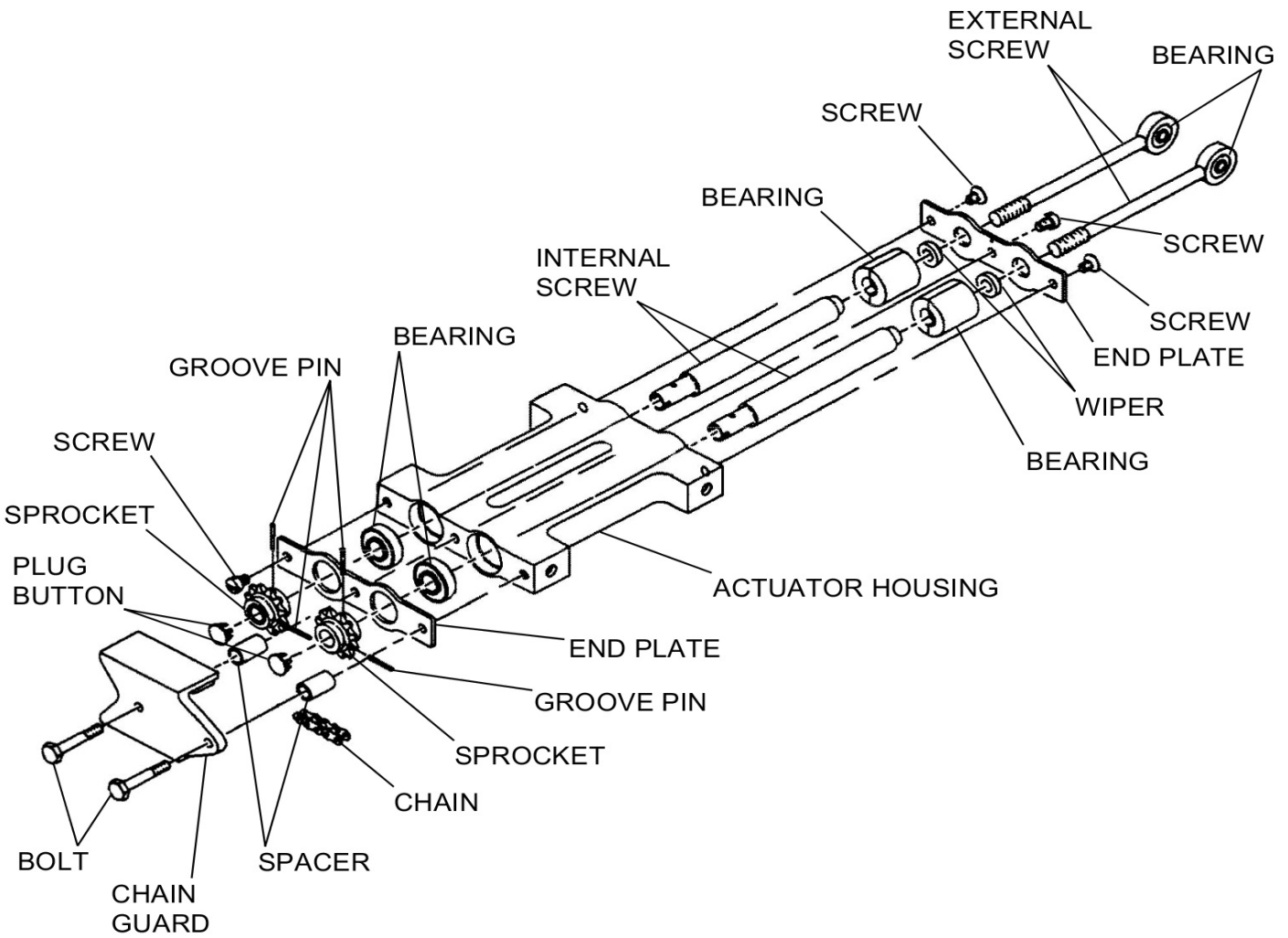

AIRPLANES 20800238 THRU 20800376 AND
AIRPLANES 208B0390 THRU 208B1055 AND
ALL SPARES

2661215-1 TRIM TAB ACTUATOR

2661R1023

Figure 202 : Sheet 5 : Elevator Trim Tab Actuator

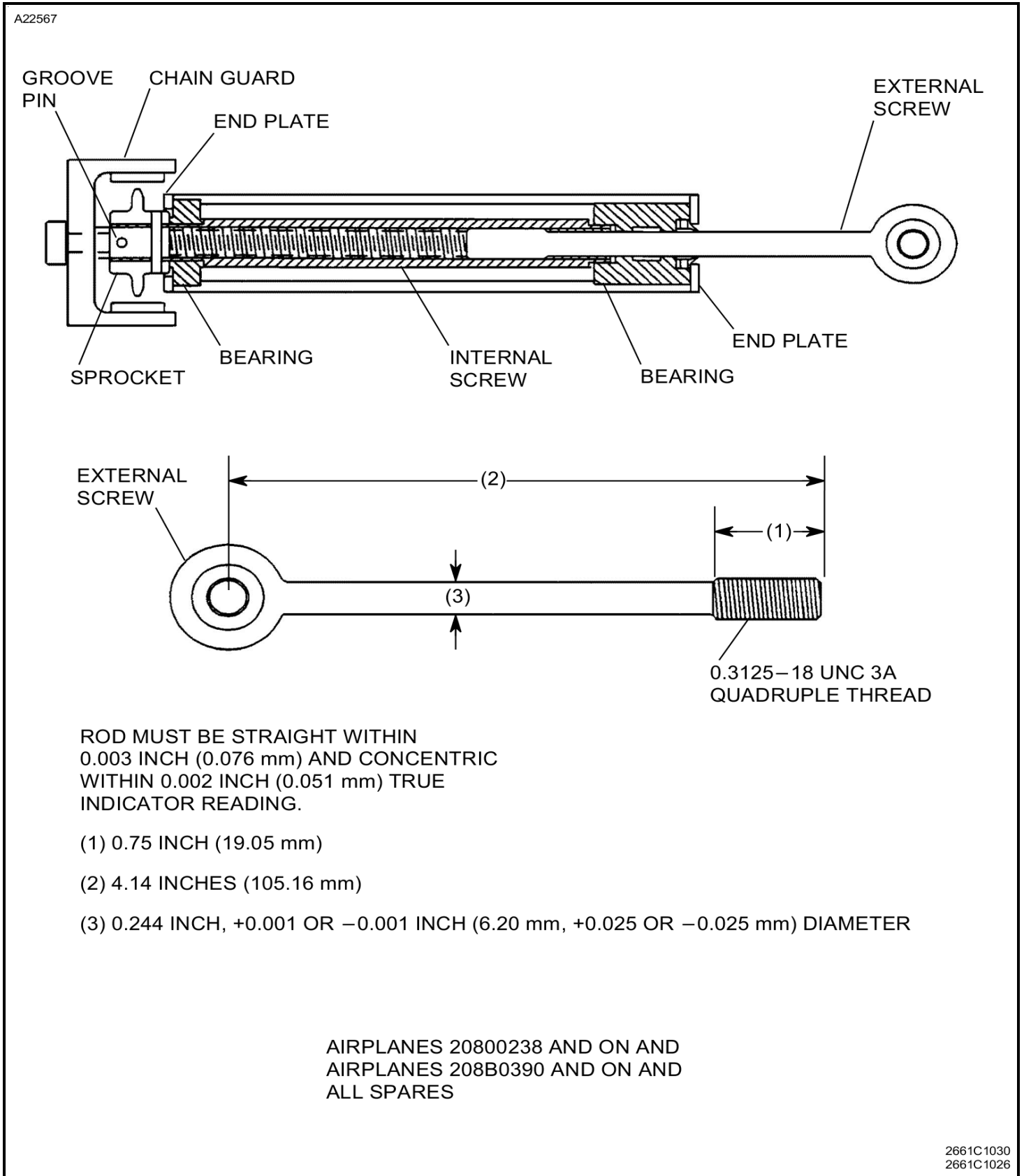
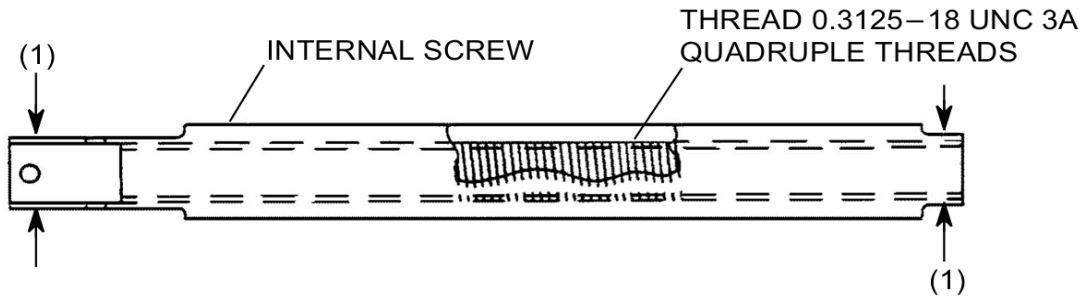
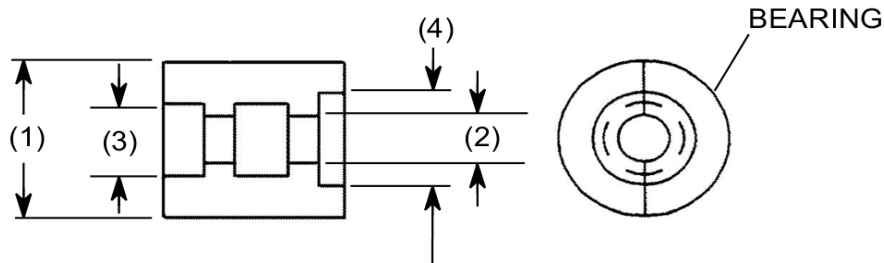

Figure 202 : Sheet 6 : Elevator Trim Tab Actuator

A22569



(1) 0.375 INCH, +0.000 OR -0.001 INCH (9.525 mm, +0.000 OR -0.025 mm) DIAMETER



(1) 0.828 INCH, +0.000 OR -0.001 INCH (21.03 mm, +0.000 OR -0.025 mm) DIAMETER

(2) 0.250 INCH, +0.001 OR -0.001 INCH (6.35 mm, +0.025 OR -0.025 mm) DIAMETER

(3) 0.385 INCH, +0.000 OR -0.000 INCH (9.78 mm, +0.000 OR -0.000 mm) DIAMETER

(4) 0.497 INCH, +0.000 OR -0.000 INCH (12.62 mm, +0.000 OR -0.000 mm) DIAMETER

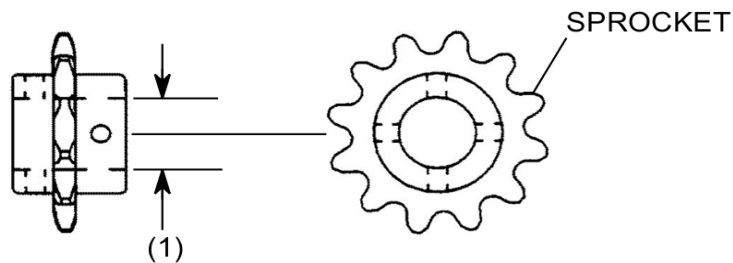

(1) 0.376 INCH, +0.001 OR -0.001 INCH (9.550 mm, +0.025 OR -0.025 mm) DIAMETER

AIRPLANES 20800238 AND ON AND
 AIRPLANES 208B0390 AND ON AND
 ALL SPARES

2661C1031
 2661C1027
 2661C1028

Figure 202 : Sheet 7 : Elevator Trim Tab Actuator

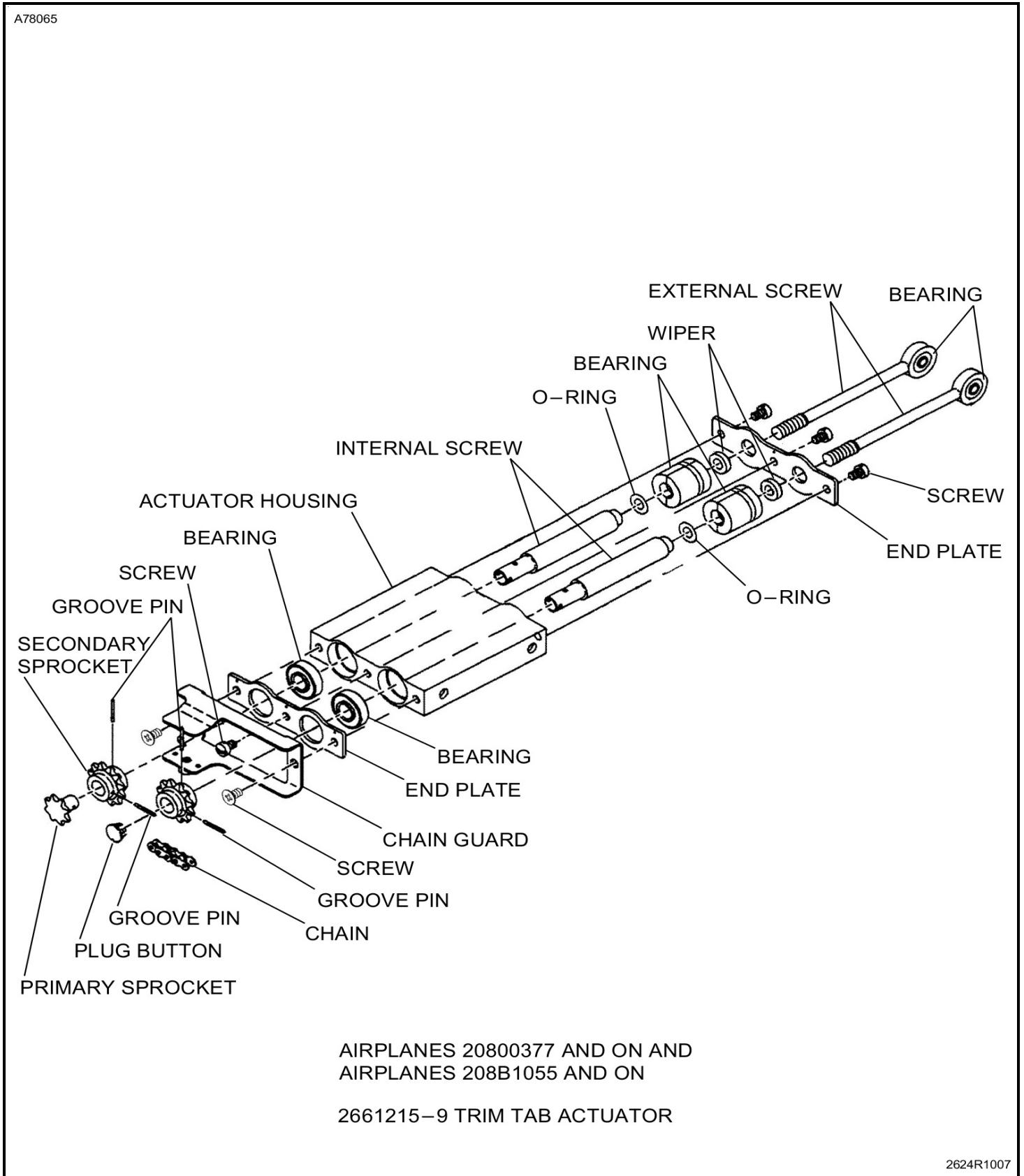

Figure 202 : Sheet 8 : Elevator Trim Tab Actuator

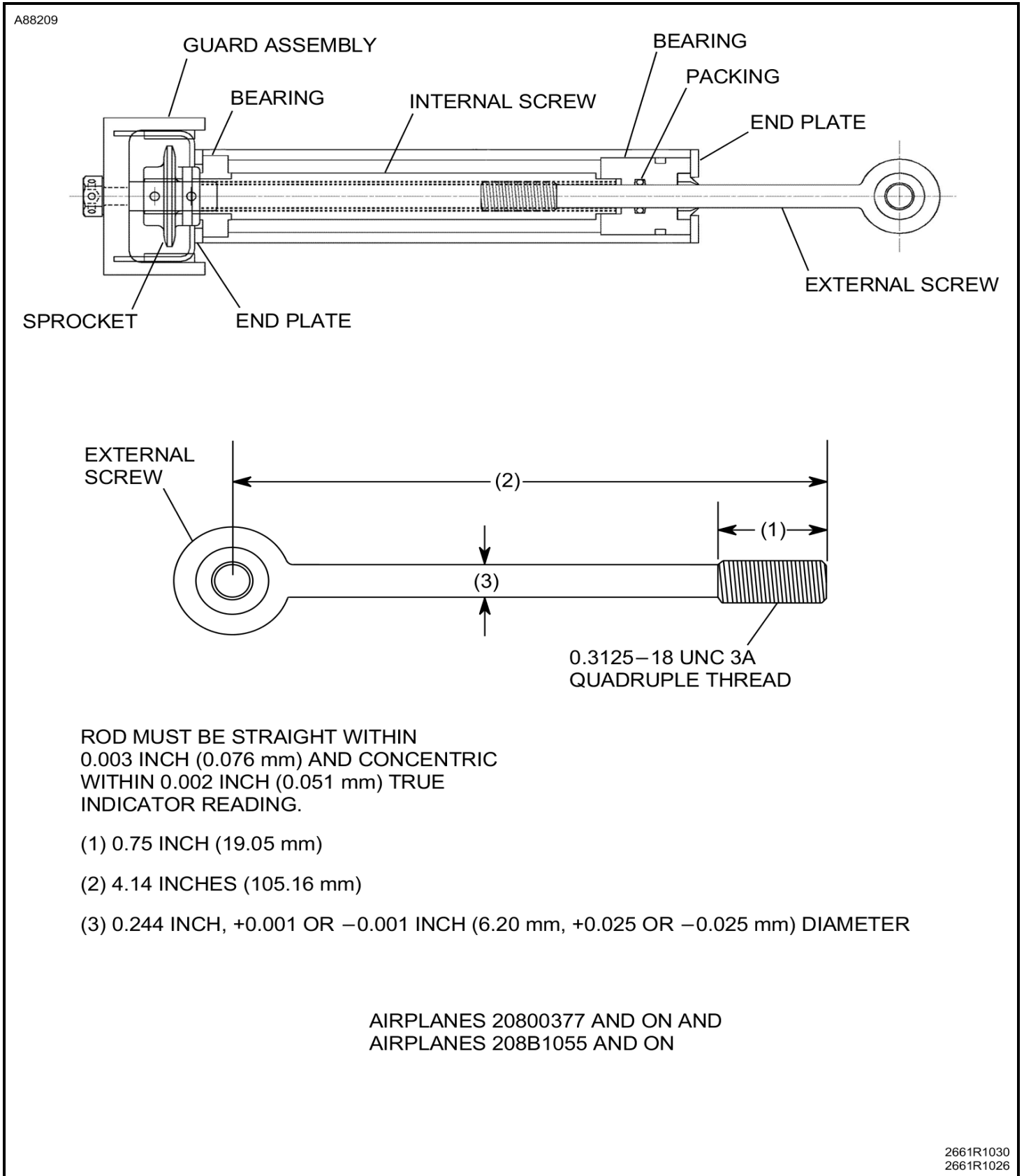
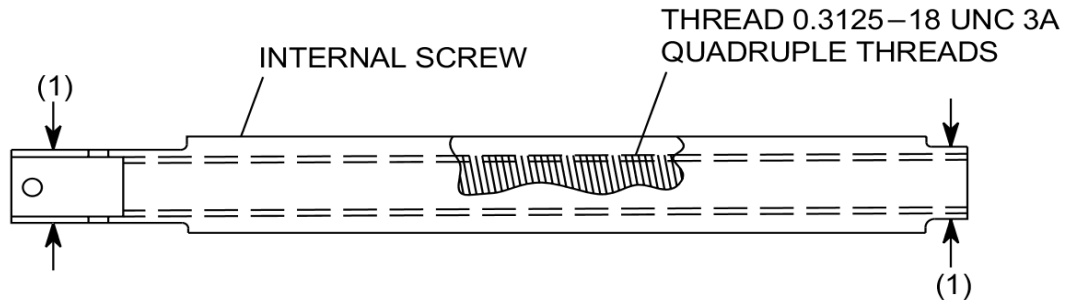
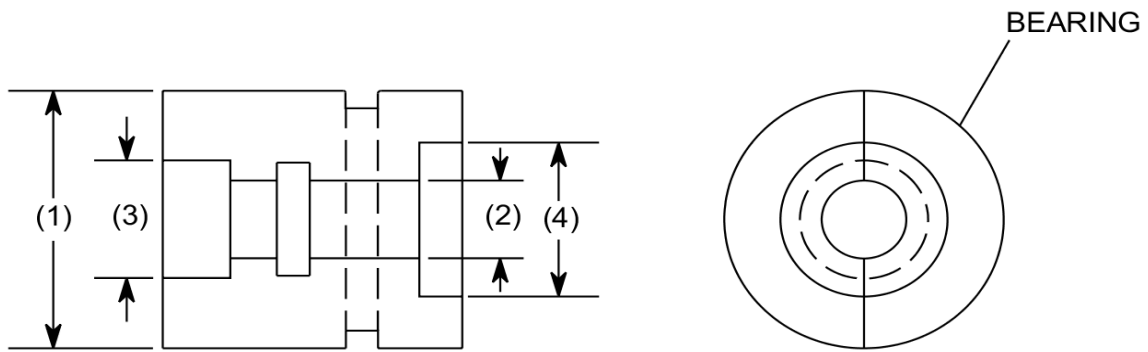

Figure 202 : Sheet 9 : Elevator Trim Tab Actuator

A88210



(1) 0.375 INCH, +0.000 OR -0.001 INCH (9.525 mm, +0.000 OR -0.025 mm) DIAMETER



(1) 0.828 INCH, +0.000 OR -0.001 INCH (21.03 mm, +0.000 OR -0.025 mm) DIAMETER

(2) 0.250 INCH, +0.001 OR -0.001 INCH (6.35 mm, +0.025 OR -0.025 mm) DIAMETER

(3) 0.380 INCH, +0.001 OR -0.000 INCH (9.652 mm, +0.025 OR -0.000 mm) DIAMETER

(4) 0.497 INCH, +0.000 OR -0.000 INCH (12.62 mm, +0.000 OR -0.000 mm) DIAMETER

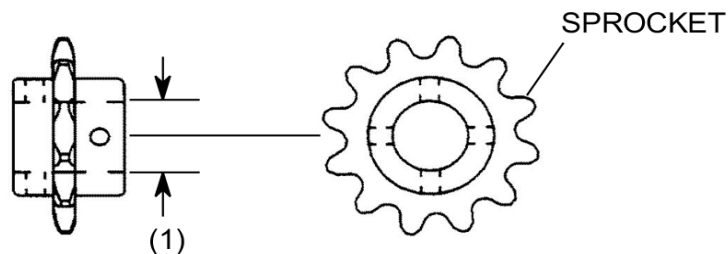

(1) 0.376 INCH, +0.001 OR -0.001 INCH (9.550 mm, +0.025 OR -0.025 mm) DIAMETER

AIRPLANES 20800377 AND ON AND
 AIRPLANES 208B1055 AND ON

2661R1031
 2661R1027
 2661R1028